



Parker Tube Fabricating Equipment

Catalog 4190 - TFE

aerospace
climate control
electromechanical
filtration
fluid & gas handling
hydraulics
pneumatics
process control
sealing & shielding



ENGINEERING YOUR SUCCESS.

Tube Fabricating Equipment

Contents

Tube Fabricating Equipment

Page 3 Small Bore Expert Training

Page 4 Benders

Page 6 Cutting & Deburring Tools

Page 8 Sealants

Page 10 Gaugeability Tools

Introduction:

At Parker, we feel that the correct tube selection and installation are key ingredients to building leak-free, reliable systems. Within this catalog is a full compliment of tube cutters, deburring, bending, and assembly equipment for use in installing tubing systems in all types of materials.

Dedication to quality at Parker is second to none. Our resources and vast product line, supported by an ISO 9001 Certified Quality Management System, is available through our worldwide distribution network. For more information regarding our tube fabrication equipment and other products and services, please contact your nearest Parker Sales Office, details found on back page.



WARNING

FAILURE, IMPROPER SELECTION OR IMPROPER USE OF THE PRODUCTS AND/OR SYSTEMS DESCRIBED HEREIN OR RELATED ITEMS CAN CAUSE DEATH, PERSONAL INJURY AND PROPERTY DAMAGE.

This document and other information from Parker Hannifin Corporation, its subsidiaries or its authorized distributors provide product and/or system options for further investigation by users having technical expertise. It is important that you analyze all aspects of your application and review the information concerning the product or system in the current product catalog. Due to the variety of operating conditions and applications for these products or systems, the user, through its own analysis and testing, is solely responsible for making the final selection of the products and systems and assuring that all performance, safety and warning requirements of the application are met.

The products described herein, including without limitation, product features, specifications, designs, availability and pricing, are subject to change by Parker Hannifin Corporation and its subsidiaries at any time without notice.

Offer of Sale

The items described in this document are available for sale by Parker Hannifin Corporation, its subsidiaries or its authorized distributors. Any sale contract entered into by Parker will be governed by the provisions stated in Parker's standard terms and conditions of sale (copy available upon request).

Join the Parker IPDE Facebook and YouTube communities





Small Bore Expert Training

Small Bore Expert training is Parker Instrumentation's training programme for small bore tubing systems.

The course has been developed as an upgrade and replacement to our industry leading Safety at Work Programme, provide material that is relevant to your sales professionals and enable them to conduct their own training sessions with their customer base.

Some of the advantages over our existing programme are:

- Greater knowledge of small bore tubing systems
- Increased product familiarity
- Improved selling and presentation ability
- Increased skills and confidence in dealing with small bore systems
- Ability to deliver chargeable training

The benefits that your nominated trainer can pass on to your customer base are:

- Increased understanding of their own systems and installation practices
- Improvements in the safety and integrity of their small bore tubing systems
- Overall asset integrity improvement

What does the Trainer get?

- 5 days of training, including:
 - 2 days of presentation training

A comprehensive kit including:

- Spanners
- Tube benders
- Tube cutter
- De-burrer
- Vice grips
- Fittings samples
- Promotional clothing
- License fee

The per delegate cost for the course is £1500 and includes all of the aforementioned items.

All ING distributors will need to have at least one certified trainer in their organisation. This will be the only licensed and certified training course that we will allow to be run with our support.

What else do you get?

- Access to the only certified IPDE training course
- A training program we can proudly market to our customers

If you would like further information relating to this training, please contact Parker Instrumentation: +44 (0) 1271 313131

Tube Benders

Parker PTB heavy duty 180° tube bender with a unique indexing handle for 1/4" to 1/2" and 6mm to 12mm tube

Tube O.D.	Bend Radius	Weight (Kg)	Part Number
Imperial			
1/4	9/16	0.54	PTB-4T
3/8	15/16	1.68	PTB-6T
1/2	1 1/2	3.45	PTB-8T
Metric			
6	14.3	0.54	PTB-6M
8	23.8	1.00	PTB-8M
10	23.8	1.68	PTB-10M
12	38.1	3.45	PTB-12M

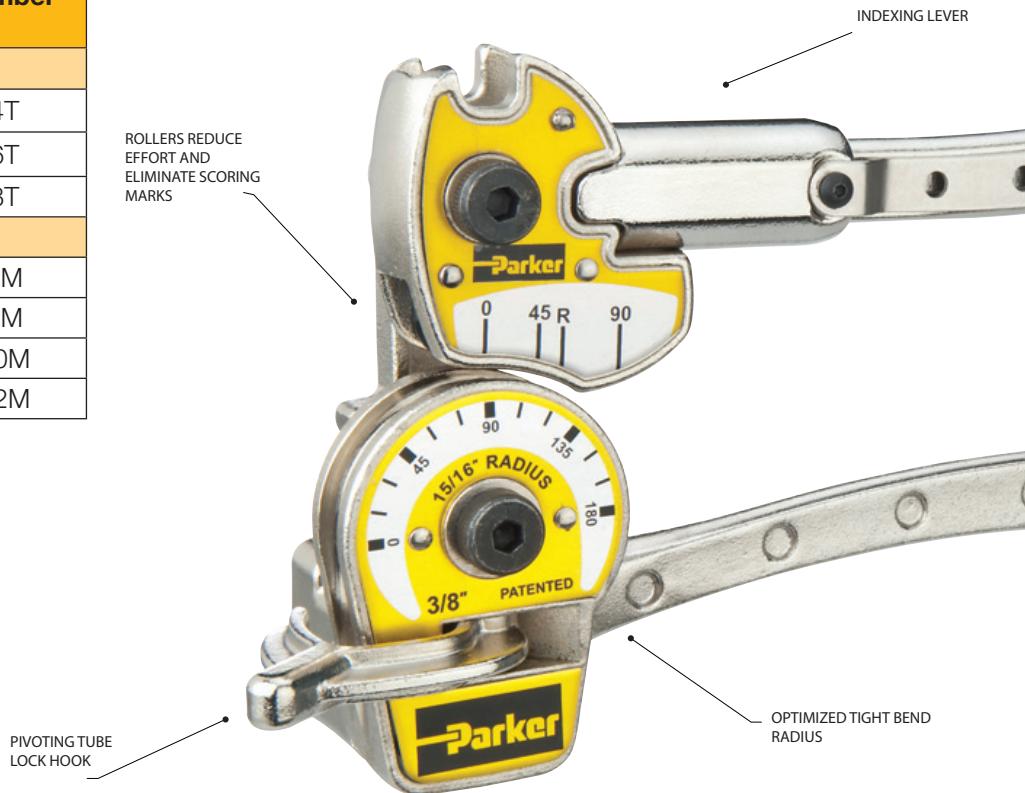

For bending soft copper, aluminum, brass, steel stainless steel

Features

- New design for accurate and tight bends up to 180° in stainless steel and other tougher metals
- Rollers in bending handle reduce friction and bending effort; eliminate scoring of tubing
- Comfortable and durable ergonomically molded cushion grips
- Vice lug for mounting in vice
- Clamshell packaging available for 1/4", 3/8", 6mm, 8mm and 10mm models
- Patented, quick action trigger release repositions two-stage handle midway through a bend when both handles meet

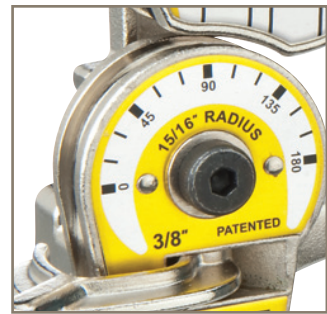

steel and other tubing

How to Order - Tube Benders

The correct part number is easily derived from the following number sequence. The two product characteristics required are coded as shown below.

PTB	4T														
Series	Tube O.D.														
PTB	<table border="0"> <tr><td>4T</td><td>1/4"</td></tr> <tr><td>6T</td><td>3/8"</td></tr> <tr><td>8T</td><td>1/2"</td></tr> <tr><td>6M</td><td>6 mm</td></tr> <tr><td>8M</td><td>8 mm</td></tr> <tr><td>10M</td><td>10 mm</td></tr> <tr><td>12M</td><td>12 mm</td></tr> </table>	4T	1/4"	6T	3/8"	8T	1/2"	6M	6 mm	8M	8 mm	10M	10 mm	12M	12 mm
4T	1/4"														
6T	3/8"														
8T	1/2"														
6M	6 mm														
8M	8 mm														
10M	10 mm														
12M	12 mm														

Cutting & Deburring Tool

Parker PTC tube cutter for 1/8" to 1-1/8" and 4mm to 28mm O.D. tubing



4-1/4" LOW PROFILE
CONSISTENT SWING
RADIUS

SELF-CLEANING
BURR REMOVAL
GROOVE



LIGHTWEIGHT ALUMINIUM BODY

ENCLOSED STEEL THRUST BEARING
FOR SMOOTH CUTTING

All tube cutters are 100% factory tested to ensure accurate spiral-free cutting.

The Parker tube cutter cuts stainless steel, soft copper, and aluminium tubing from 1/8 to 1-1/8 in. and 4 to 28 mm O.D.

Features

- Lower profile swing radius - 4-1/4"
- Rollers feature flare cut-off groove to reduce tube loss when damaged flare is removed
- Lightweight die-cast solid aluminium body
- Enclosed hardend steel, thrust bearing feed mechanism for smoothest cutting action and trouble free operation
- Cutter wheels are made of the highest quality wear and abrasion-resistant steel and precision machined to exacting specifications for accurate cutting and long life
- Unique design eliminates spiraling for clean right angle cuts
- Durable low gloss black wrinkle finish for improved wear resistance

Parker PTD Inner-Outer Reaming and Deburring Tools, for 3/16" to 1-1/2" O.D. tubing

A quick twist of the wrist will deburr either the O.D. or the I.D. of the tube end. Parker's deburrer can be used on annealed steel, stainless steel, copper or aluminium, for tube sizes 3/16" to 1-1/2" O.D.

Insert the tube into the convexed end of the deburrer for inside deburring and the opposite end for outside deburring. Rotate in either direction.

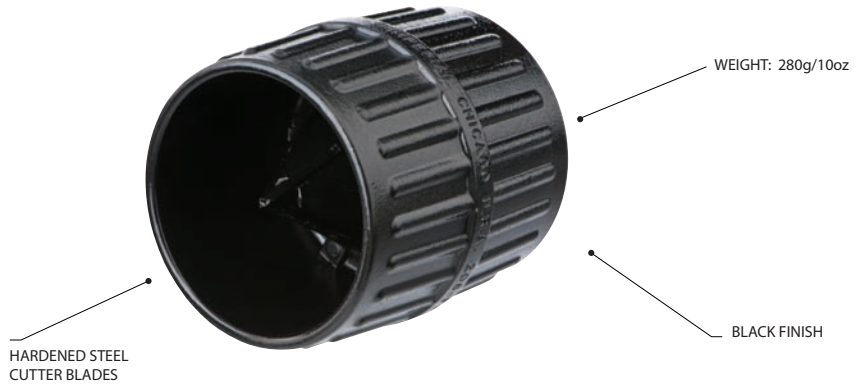

Features

- Reams both inside and outside edges of tube with 3 hollow ground cutters
- Tough die cast body
- Replacement blades can be ordered
- Deburrs both clockwise and anti-clockwise
- Fluted body is shaped to fit comfortably in palm

Parker PTV Tru-Kut Sawing Vice

Hacksaw guide will accommodate tube, pipe and hose from sizes 3 (3/16" O.D.) to 32 (2" O.D.). Assures square cut-offs within $\pm 1^\circ$. Use a fine tooth hacksaw blade for smoother cuts.

How To Use: Mount in vice or bolt to bench. Clamp tubing, pipe or hose into the Tru-Kut vice and cut off; guide ensures accurate square cuts.

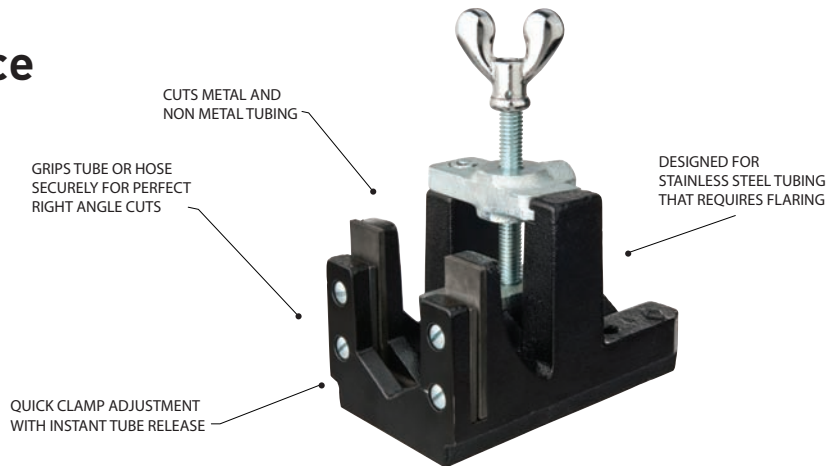

How to Order - Cutters, Deburrers and Vices

The correct part number is easily derived from the following number sequence. The two product characteristics required are coded as shown below.

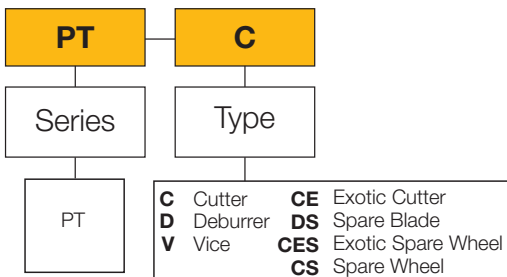

Sealants

Parker PSL LOCTITE® 567™

A high performance sealant that locks and seals metal, tapered pipe threads and fittings. Ideal for stainless steel, aluminum, galvanized metal and other inert metals, 567™ has excellent solvent resistance and withstands temperatures to 204°C (400°F).



DESIGNED FOR THE LOCKING AND SEALING OF METAL TAPERED THREADS AND FITTINGS

Features

- High lubricating properties of this compound prevent galling on stainless steel, aluminum and all other metal pipe threads and fittings
- Recommended for industrial applications in the chemical processing, petroleum refining, pulp/paper, waste treatment, textile, utilities/power generation, marine, automotive, industrial equipment, gas compression and distribution industries.

Parker PSP Sealant

Sealing with Parker's solvent-free, liquid gasking compounds represents a technological advanced solution. Curing in the absence of air, which occurs after contact with metal, is the outstanding feature of anaerobic gasking compounds. As with any sealant and lubrication, safety precautions are always advised.

These sealants are available in 50ml and 200ml sizes.

Features

- Quick-curing
- Solvent free
- One component sealant
- Serves to seal threaded connections, flanges, housings and covers
- Wide temperature range
- Resistant to chemicals and solvents

EASY AND CLEAN APPLICATION



UNIQUE PARKER BRANDED SEALANT

TEMPERATURE RESISTANCE FROM -60°C TO +150°C

PTFE Tape

Polytetrafluoroethylene, or PTFE, film is cut to specified widths for use in sealing pipe threads. The tape is wrapped around the exposed threads of a pipe before it is screwed into place.

The tape is commonly used commercially in pressurised water systems as well as in air compression equipment and thread joints with coarse threads.

One of the defining characteristics of PTFE is how good it is at defeating friction. The use of PTFE tape in tapered pipe threads performs a lubricating function, which more easily allows the threads to be screwed together, to the point of deformation, which is what creates the seal.



Part Number: PS - PTFE

How to Order - Sealants

The correct part number is easily derived from the following number sequence. The three product characteristics required are coded as shown below.

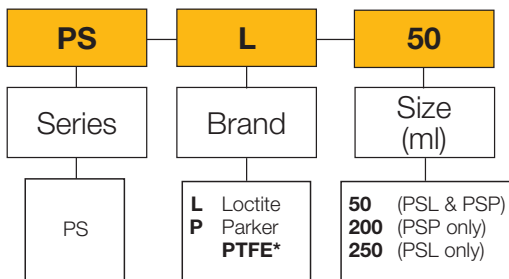

* No size required

Gaugeability Tools

Parker PTM Tube Marker

Put burnish marks on the tubing quickly and accurately with this easy-to-use tube marker. Also used to check the burnish mark position. (Good for the life of the fitting).

Ensures correct tube depth insertion into the fitting body.

How to Order - Tube Marker

The correct part number is easily derived from the following number sequence. The two product characteristics required are coded as shown below.

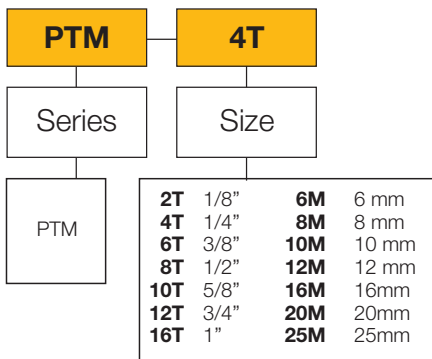

Parker PPT Preassembly Tool

How To Use: Slide nut and ferrule(s) onto tube. Set tube into presetting tool, and bottom tube against shoulder tool. Finger tighten the nut and then tighten the nut 1 turn with a wrench. Remove tube from tool. Advance the nut so it is finger-tight.

Advance the nut 1/2 turn. If torque rise is not felt in 1/4 turn, turn the nut to torque rise, loosen the nut to finger-tight, and makeup nut 1/2 turn.

How to Order - Preassembly Tool

The correct part number is easily derived from the following number sequence. The two product characteristics required are coded as shown below.

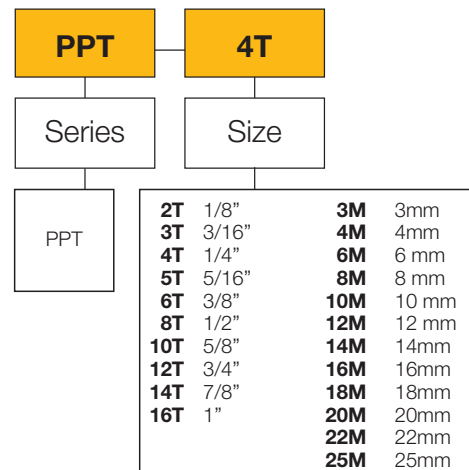

Parker PT Inspection Gauges

This unique to Parker combination gauge has dual purpose. Use the Go/No Go portion (on one end) to check the tube insertion depth. Use the other end to check the space between the nut and body hex. (Correct initial make-up prevents the gauge from being inserted).

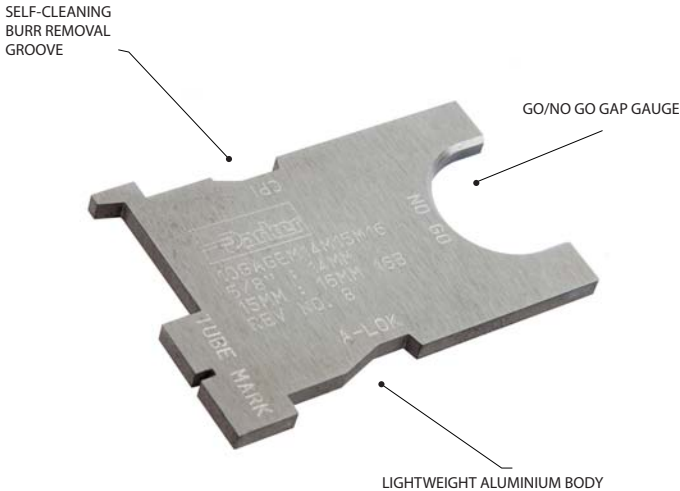

How to Order - PT Combination Gauge

The correct part number is easily derived from the following number sequence. The three product characteristics required are coded as shown below.

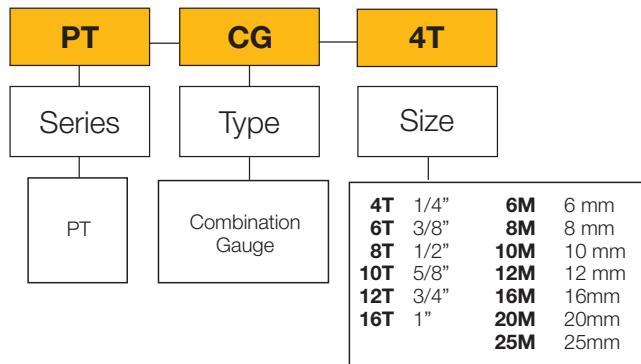

This compact C-Ring gap gauge is for imperial and metric sizes. It effectively checks the gap dimensions for correct initial make-up. All sizes can be combined on a key ring for easy handling.



How to Order - PT Gap Gauge

The correct part number is easily derived from the following number sequence. The three product characteristics required are coded as shown below.

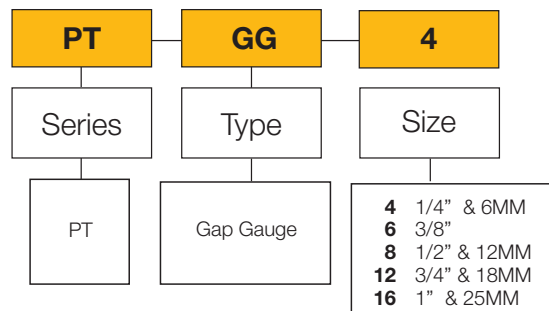

Parker Worldwide

AE – UAE, Dubai
Tel: +971 4 8875600
parker.me@parker.com

AR – Argentina, Buenos Aires
Tel: +54 3327 44 4129

AT – Austria, Wiener Neustadt
Tel: +43 (0)2622 23501-0
parker.austria@parker.com

AT – Eastern Europe,
Wiener Neustadt
Tel: +43 (0)2622 23501 970
parker.easteurope@parker.com

AU – Australia, Castle Hill
Tel: +61 (0)2-9634 7777

AZ – Azerbaijan, Baku
Tel: +994 50 2233 458
parker.azerbaijan@parker.com

BE/LX – Belgium, Nivelles
Tel: +32 (0)67 280 900
parker.belgium@parker.com

BR-Brazil, São José dos Campos
Tel: 0800 7275374
falecom@parker.com

BY – Belarus, Minsk
Tel: +375 17 209 9399
parker.belarus@parker.com

CA – Canada, Grimsby, Ontario
Tel +1 905-945-2274
ipd_canada@parker.com

CH – Switzerland, Etoy
Tel: +41 (0) 21 821 02 30
parker.switzerland@parker.com

CN – China, Shanghai
Tel: +86 21 5031 2525

CZ – Czech Republic, Klecany
Tel: +420 284 083 111
parker.czechrepublic@parker.com

DE – Germany, Kaarst
Tel: +49 (0)2131 4016 0
parker.germany@parker.com

DK – Denmark, Ballerup
Tel: +45 43 56 04 00
parker.denmark@parker.com

ES – Spain, Madrid
Tel: +34 902 33 00 01
parker.spain@parker.com

FI – Finland, Vantaa
Tel: +358 (0)20 753 2500
parker.finland@parker.com

FR – France, Contamine s/Arve
Tel: +33 (0)4 50 25 80 25
parker.france@parker.com

GR – Greece, Athens
Tel: +30 210 933 6450
parker.greece@parker.com

HK – Hong Kong
Tel: +852 2428 8008

HU – Hungary, Budapest
Tel: +36 1 220 4155
parker.hungary@parker.com

IE – Ireland, Dublin
Tel: +353 (0)1 466 6370
parker.ireland@parker.com

IN – India, Mumbai
Tel: +91 22 6513 7081-85

IT – Italy, Corsico (MI)
Tel: +39 02 45 19 21
parker.italy@parker.com

JP – Japan, Fujisawa
Tel: +(81) 4 6635 3050

KR – South Korea, Seoul
Tel: +82 2 559 0400

KZ – Kazakhstan, Almaty
Tel: +7 7272 505 800
parker.easteurope@parker.com

LV – Latvia, Riga
Tel: +371 6 745 2601
parker.latvia@parker.com

MX – Mexico, Apodaca
Tel: +52 81 8156 6000

MY – Malaysia, Shah Alam
Tel: +603-78490800

NL – The Netherlands,
Oldenzaal
Tel: +31 (0)541 585 000
parker.nl@parker.com

NO – Norway, Stavanger
Tel: +47 (0)51 826 300
parker.norway@parker.com

NZ – New Zealand, Mt Wellington
Tel: +64 9 574 1744

PL – Poland, Warsaw
Tel: +48 (0)22 573 24 00
parker.poland@parker.com

PT – Portugal, Leca da Palmeira
Tel: +351 22 999 7360
parker.portugal@parker.com

RO – Romania, Bucharest
Tel: +40 21 252 1382
parker.romania@parker.com

RU – Russia, Moscow
Tel: +7 495 645-2156
parker.russia@parker.com

SE – Sweden, Spånga
Tel: +46 (0)8 59 79 50 00
parker.sweden@parker.com

SG – Singapore,
Tel: +65 6887 6300

SK – Slovakia, Banská Bystrica
Tel: +421 484 162 252
parker.slovakia@parker.com

SL – Slovenia, Novo Mesto
Tel: +386 7 337 6650
parker.slovenia@parker.com

TH – Thailand, Bangkok
Tel: +662 717 8140

TR – Turkey, Istanbul
Tel: +90 216 4997081
parker.turkey@parker.com

TW – Taiwan, Taipei
Tel: +886 2 2298 8987

UA – Ukraine, Kiev
Tel: +380 44 494 2731
parker.ukraine@parker.com

UK – United Kingdom,
Barnstaple
Tel: +44 (0)1271 313131
parker.uk@parker.com

US – USA, Cleveland
Tel: +1 216 896 3000

ZA – South Africa,
Kempton Park
Tel: +27 (0)11 961 0700
parker.southafrica@parker.com

European Product Information Centre
Free phone: 00 800 27 27 5374
(from AT, BE, CH, CZ, DE, DK, EE, EI, ES, FI,
FR, IT, NL, NO, PL, RU, SE, SK, UK, ZA)

© 2010 Parker Hannifin Corporation. All rights reserved



Parker Hannifin Ltd
Instrumentation Products
Division Europe
Riverside Road
Pottington Business Park
Barnstaple, Devon, EX31 1NP
United Kingdom
Tel.: +44 (0) 1271 313131
Fax: +44 (0) 1271 373636
www.parker.com/ipd

Parker Hannifin Corporation
Instrumentation Products Division
1005 A Cleaner Way
Huntsville
Alabama
AL 35805
USA
Tel: + 1 (256) 881-2040
Fax: + 1 (256) 881-5072
www.parker.com/ipdus

Catalog 4190-TFE 01.11